

ConSep System

Integrated filtration Chip & Coolant System

Economical / less space / modular

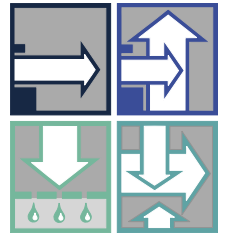

ConSep2000® II HP The integrated filtration solution

The famous ConSep 2000® System is now improved by integration of a unique indexing filterdrum. The capability of the ConSep 2000® to handle all chips types and various materials has of course remained. Filtration direct at the machine tool is not only space saving, but allows the design of a compact system to achieve optimised coolant cleaning.

The new ConSep 2000® II HP reduces the required preventive maintenance interventions and therefore improves the up-time performance of the coolant system. ConSep 2000® II HP is the ultimate solution for chip handling and integrated coolant cleaning at machining centers, multi-spindle lathes and in particular the high performance integrated lathes.

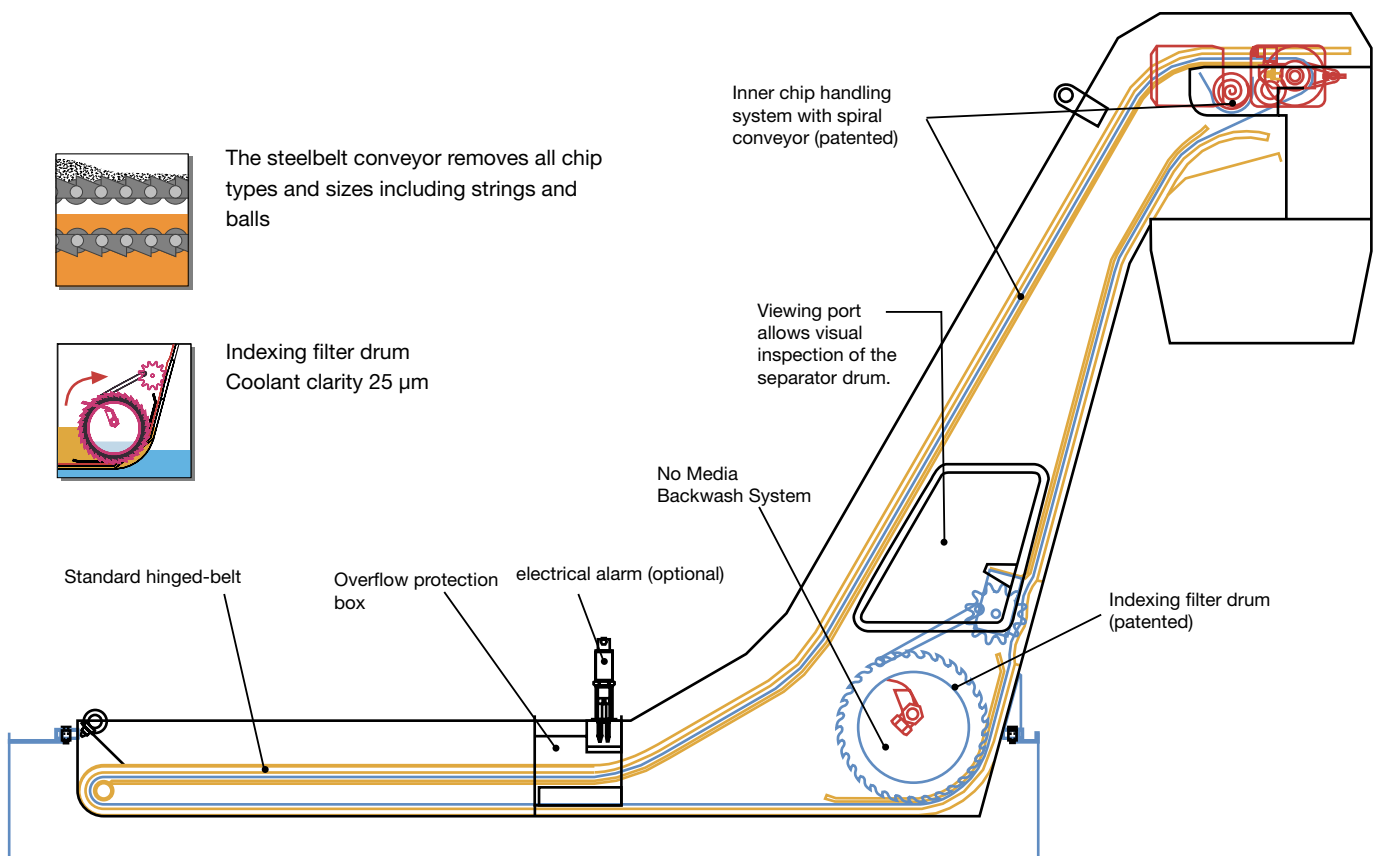

Designed and engineered to worldwide standards

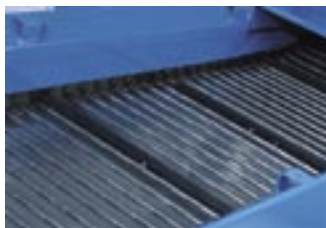
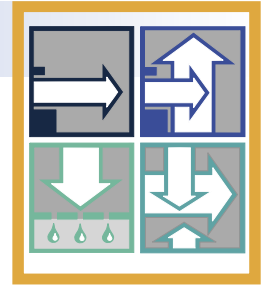

Steel belt conveyor



Auger

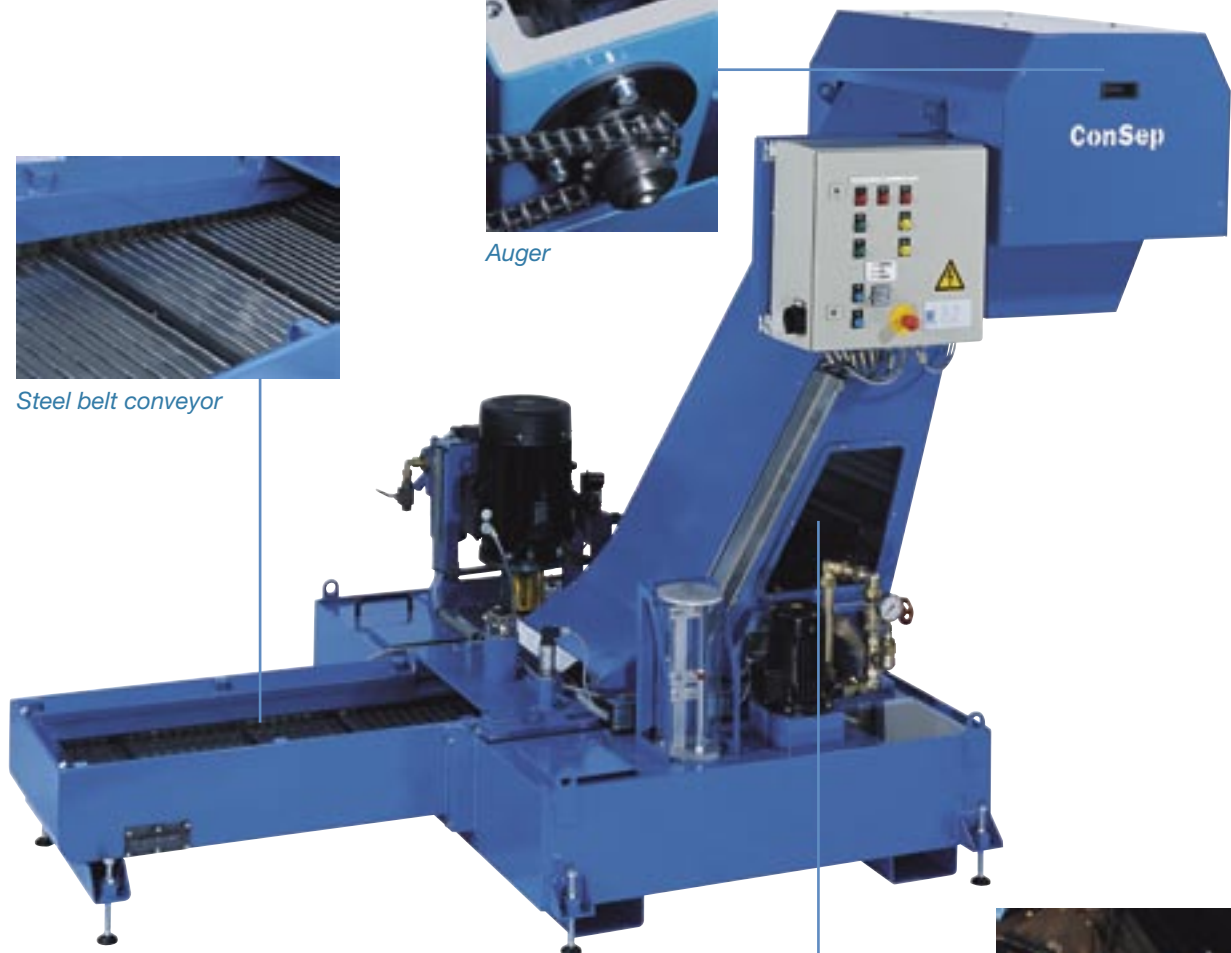

Indexing drum filtration



- Improved coolant cleaning capabilities
- Handling all type of chips and various materials is secured by the steelbelt.
- Protection by the steelbelt prevents damage of the filtration mesh by long, nasty chips and increases the availability of the coolant cleaning system.
- Fines and sediments are handled through a unique inner chip handling system with a spiral conveyor at the discharge.

Modular system design allows ...

ConSep 2000® II HP meets your individual coolant
cleaning requirements now or later



AT-Cleaner

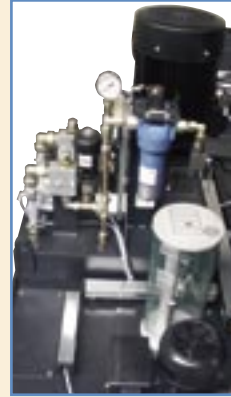

*High-Pressure
Pump Package*

High pressure coolant system

Engineered systems offer 55 l/min,
20-100 bar (15 GPM @ 300-1500 PSI)

- Variable flow and pressure
- Police filter optional

Secondary coolant cleaning

The AT-Cleaner is a hydraulic centrifugal separator requiring no disposable filter media.

- Extends tool life and surface quality
- Minimizes manual cleaning maintenance



Electrical Controls

Plug and run controls

- Simple integration into existing machine tool controls
- SPS logic control



Oil skimmer

Separation of foreign/tramp oils

- Skimmer separates floating foreign or tramp oils from the coolant



... for additional coolant cleaning components

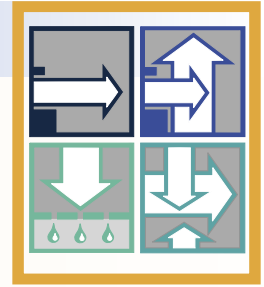

SF2 AT-Cleaner for sludge clean-out

Minimized sedimentation in tanks

- Automatically removes sludge and dirt
- Minimal maintenance



Chiller Unit

For improved machining tolerances

- Through coolant refrigeration
- Temperature regulating system



Separate coolant tank

For increased coolant storage volumes

- Extended coolant filling cycles
- Weekend stand-by mode
- Improved heat dissipation

Integrated clean coolant tank

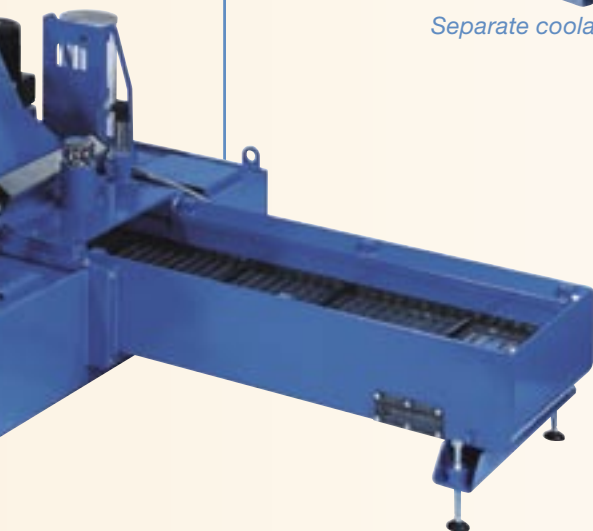

Wash gun package

For manual cleaning purposes of machines parts or machine positions, a wash gun can be used. The washgun package is based on an air driven positive displacement pump, requires no electrical controls and consumes minimal space

Fluid System 2000

Meet automotive requirements...

- Optimized for 24/7 shift operations
- Highest machine availability
- Minimized space requirements
- modular design
- Lower operation costs
- NO factory floor infrastructure investments
- Extends coolant life

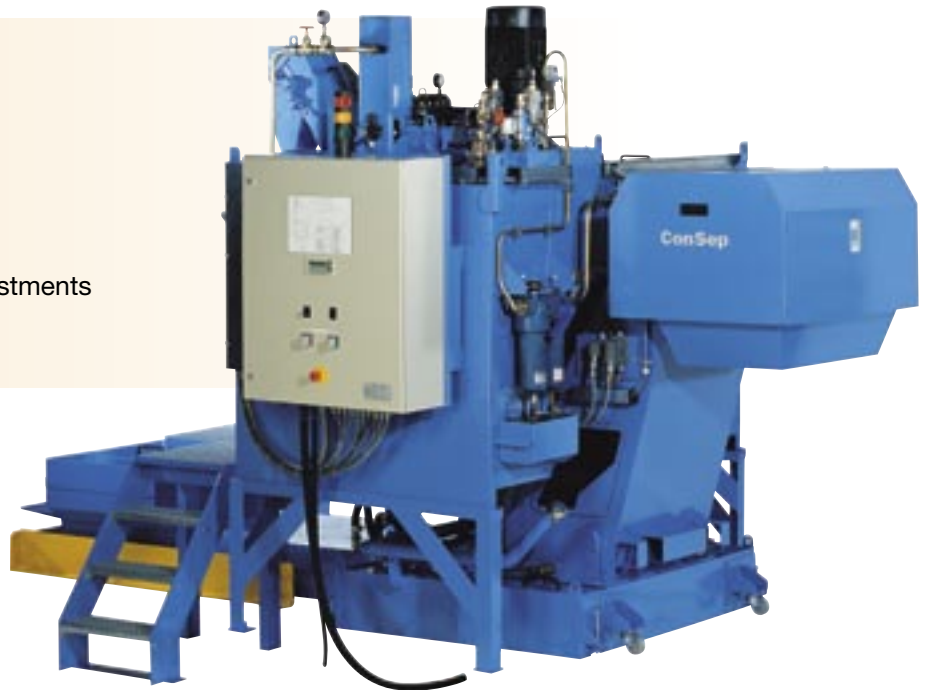

Basic system components

ConSep 2000II Universal chip removal technology & automatic filter system

- Heavy duty steel belt conveyor
- Medium free INDEXING filter drum
- Suitable for all metal chips

Pumpback type lift tank with robust coolant lift pump FS 2000 Coolant storage tank (V-shape)

- Mayfran LCD level control device
- Manual (re)-fill connection
- Quick system drain feature for coolant disposal

Optional components

Pump technology for the machine

- High pressure packages up to 120 bars
- Low pressure machine wash packages
- Coolant gun for manual machine/part washing

Coolant cleaning Secondary by-pass filtration packages

- for through spindle high pressure circuit only
- for automatic coolant tank cleaning
- for automatic coolant tank cleaning & through spindle high pressure circuit

Coolant input control Automatic coolant mixing devices

- 2 phase mixing units
- 3 phase mixing units

Coolant conditioning Surface cleaning

- Oil surface skimmer packages
- 2-3 phase sludge centrifuges
- Aeration packages

Machining accuracy Coolant refrigeration

- Submerged type refrigerator fixed or ambient temperature control



coolant surface cleaner

ConSep 2000®

For special applications we use our proven ConSep 2000 System with steelbelt and draglink conveyor

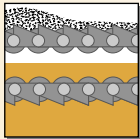
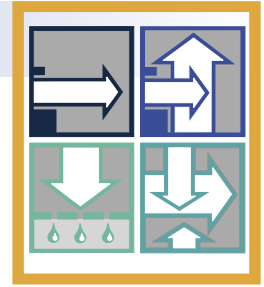

The primary conveyor removes all chip types and sizes including strings and balls

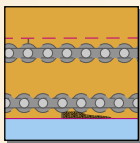

The lower drag-type separator conveyor removes fines that are passed through and carried back into the system by the primary conveyor

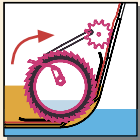

New back wash system separates fines from the coolant to 25 micron nominal

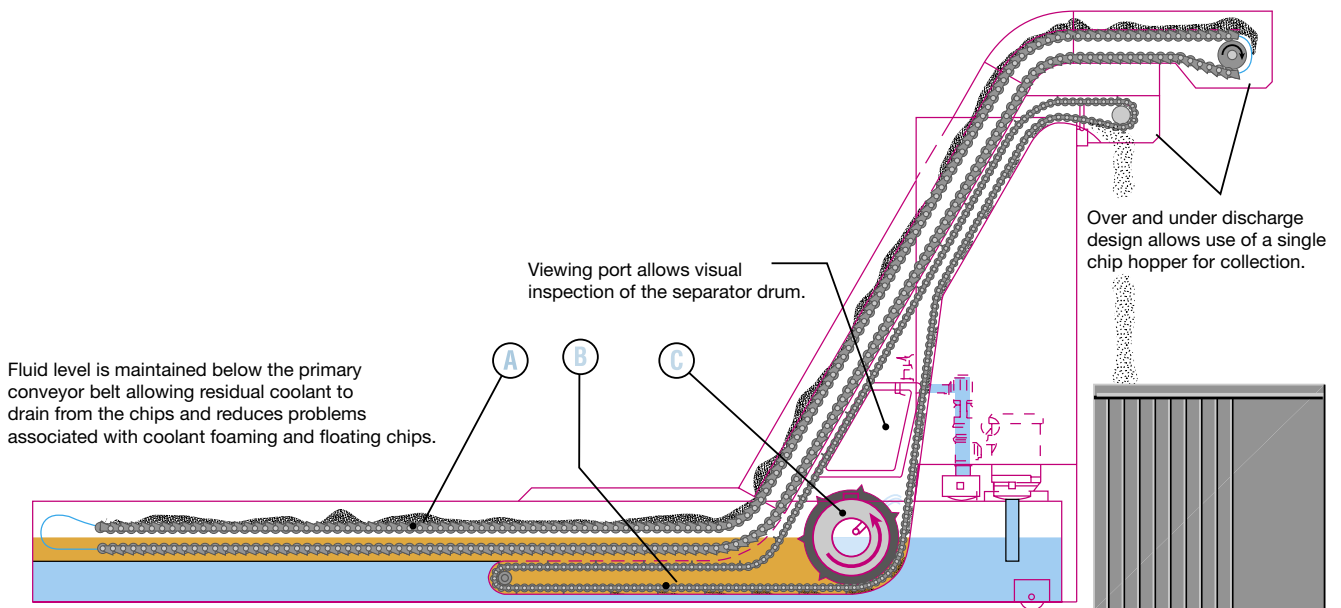
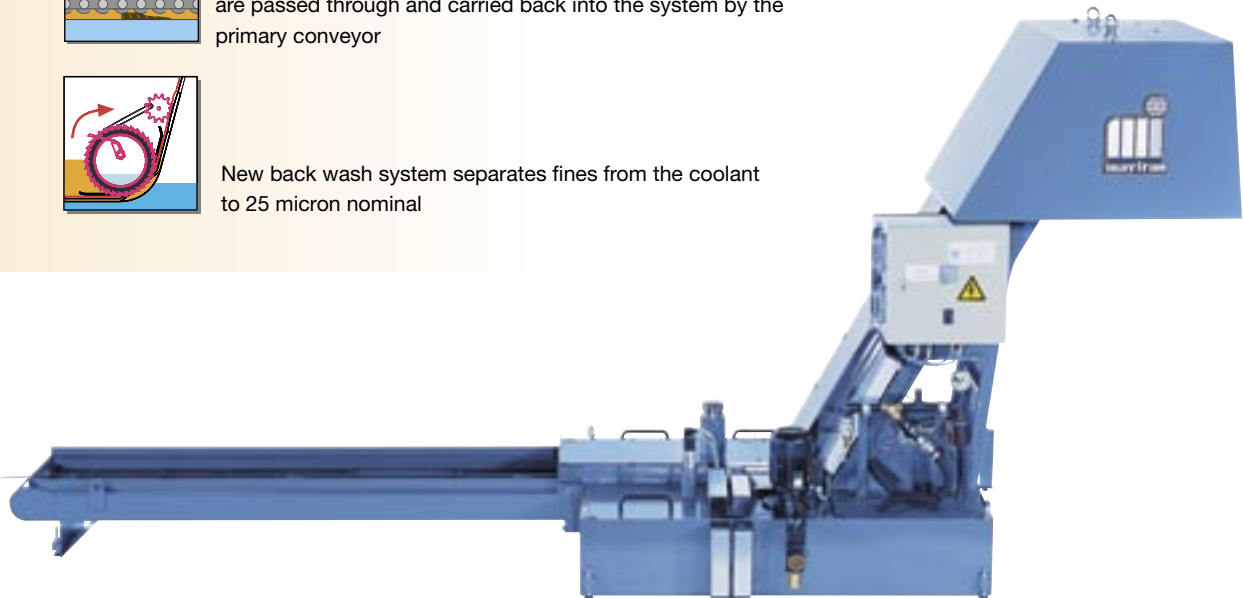

WORLDWIDE AT YOUR SIDE...



MAYFRAN INTERNATIONAL (INC.)

P.O. Box 43038
Cleveland, OH 44143 U.S.A.
Tel.: +1 44 04 61 41 00
Fax: +1 44 04 61 55 65
info@mayfran.com
www.mayfran.com



MAYFRAN GMBH

Hüttenstraße 7
D-52068 Aachen / Germany
Tel.: +49 2 41 93 87 20
Fax: +49 2 41 17 50 80
sales@mayfran.eu
www.mayfran.de



MAYFRAN U.K. LTD.

Unit 38 Bradley Fold Trading Estate
Bradley Fold Road, Radcliff, Bury BL2 6RT
United Kingdom
Tel.: +44 12 04 36 64 69
Fax: +44 12 04 36 68 40
sales@mayfran.co.uk
www.mayfran.co.uk



MAYFRAN INTERNATIONAL B.V.

P.B. 31032, Edisonstraat 7
6370 AA Landgraaf / Netherlands
Tel.: +31 4 55 32 92 92
Fax: +31 4 55 32 93 00
sales@mayfran.eu
www.mayfran.com



NIEDERLASSUNG SÜD

Richthofenstraße 32
D-73312 Geislingen / Steige
Tel.: +49 7 33 19 55 30
Fax: +49 7 33 19 55 355
sales@mayfran.eu
www.mayfran.de



MAYFRAN FRANCE S.A.R.L.

Centre D'Affaires, Paris-Nord
Immeuble l' Ampère,
F-93153 Le Blanc Mesnil Cedex / Frankreich
Tel.: +33 1 48 65 78 00
Fax: +33 1 48 65 66 55
sales@mayfran.fr
www.mayfran.fr



TSUBAKIMOTO MAYFRAN INC.

5001 Ohno, Tsuchiyama-cho, Koka-shi
Shiga 528-0235 / Japan
Tel.: +81 7 48 67 10 01
Fax: +81 7 48 67 10 97
www.mayfran.co.jp



KOREA MAYFRAN

68B-7L Namdong Industrial Estate
627-3 Gojan-dong Namdong-gu.
Incheon 405-817. Korea
Tel.: +82 32 822 58 86
Fax: +82 32 822 91 66
sales@mayfran.co.kr
www.mayfran.co.kr



MAYFRAN CHINA

Tsubakimoto Mayfran Conveyor
(Shanghai) Co., Ltd.
Building 2, 1300 Bei He Rd.
Jinding Industry Zone
Shanghai 201807 / China
Tel.: +86 21 39 53 86 56
Fax: +86 21 39 53 86 19
rshum@mayfran.com.cn
www.mayfran.com.cn



MAYFRAN CZ S.R.O.

Troská 14
180 00 Praha 8 / Czech Republic
Tel.: +420 241 48 51 31
Fax: +420 241 48 51 32
sales@mayfran.eu
www.mayfran.cz



MIVEN MAYFRAN

Miven Mayfran Conveyors Pvt. Ltd.,
Sirurs Compound, Karwar Road,
Hubli-580 024, Karnataka, India
Tel.: +91 836 221 22 01
Fax: +91 836 230 32 65
info@mivenmayfran.com
www.mivenmayfran.com